

# Technical data sheet

## Product features



### Cooking range induction 2 zones

<b>Model</b>	<b>SAP Code</b>	00013591
--------------	-----------------	----------



- Device type: Electric unit
- Power consumption of the zone 1 [kW]: 5
- Power consumption of the zone 2 [kW]: 5
- Protection of controls: IPX5
- Material: Stainless steel

<b>SAP Code</b>	00013591	<b>Loading</b>	400 V / 3N - 50 Hz
<b>Net Width [mm]</b>	400	<b>Number of zones</b>	2
<b>Net Depth [mm]</b>	800	<b>Power consumption of the zone 1 [kW]</b>	5
<b>Net Height [mm]</b>	422	<b>Power consumption of the zone 2 [kW]</b>	5
<b>Net Weight [kg]</b>	20.00	<b>Ceramic glass dimensions [mm x mm]</b>	350 x 770
<b>Power electric [kW]</b>	10.000		

# Technical data sheet

Technical drawing



Cooking range induction 2 zones

Model

SAP Code

00013591

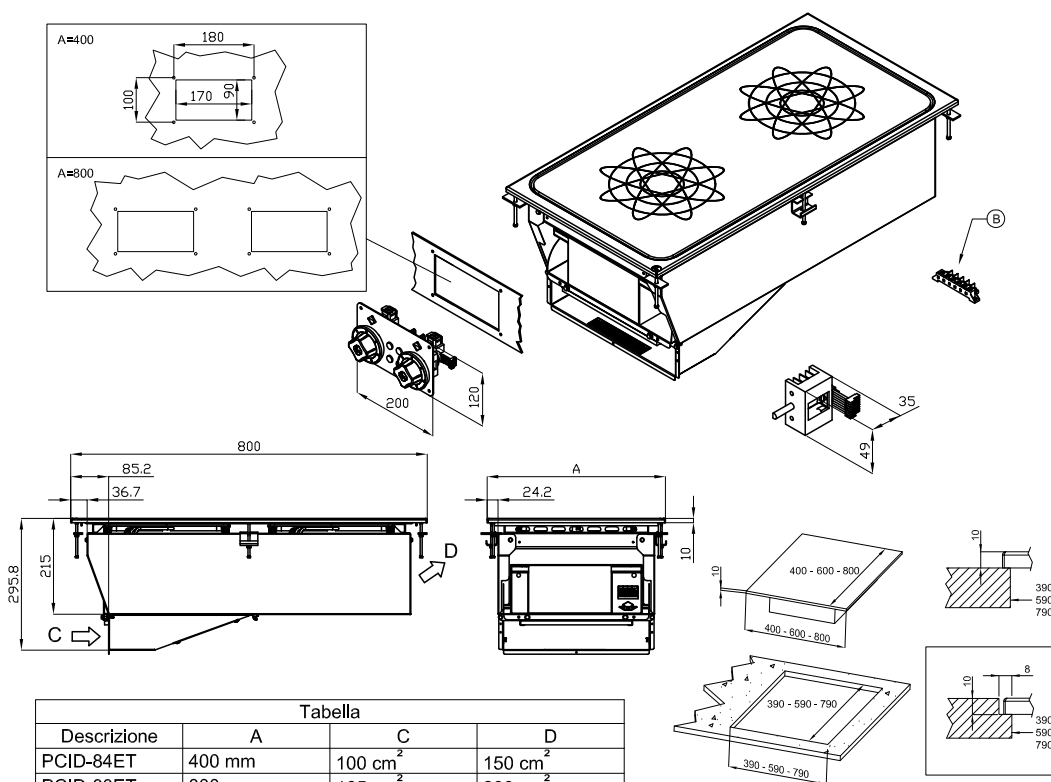

A	Data plate		B	Electrical connection	
---	------------	--	---	-----------------------	--

# Technical data sheet

Technical parameters



## Cooking range induction 2 zones

**Model**

**SAP Code**

00013591

**1. SAP Code:**

00013591

**2. Net Width [mm]:**

400

**3. Net Depth [mm]:**

800

**4. Net Height [mm]:**

422

**5. Net Weight [kg]:**

20.00

**6. Gross Width [mm]:**

430

**7. Gross depth [mm]:**

970

**8. Gross Height [mm]:**

540

**9. Gross Weight [kg]:**

25.00

**10. Device type:**

Electric unit

**11. Construction type of device:**

Drop-in

**12. Power electric [kW]:**

10.000

**13. Loading:**

400 V / 3N - 50 Hz

**14. Protection of controls:**

IPX5

**15. Material:**

Stainless steel

**16. Worktop type:**

Molded - comfortable cleaning maintenance

**17. Worktop material:**

AISI 304

**18. Worktop Thickness [mm]:**

2.00

**19. Number of zones:**

2

**20. Power consumption of the zone 1 [kW]:**

5

**21. Power consumption of the zone 2 [kW]:**

5

**22. Power control type:**

knob control

**23. Number of power control stages:**

6

**24. Service accessibility:**

From the front by removing the front panel and waste fluid containers

**25. Number of burners/hot plates:**

2

**26. Type of electric cooking zones:**

Induction

**27. Ceramic glass dimensions [mm x mm]:**

350 x 770